

## Subject: Motor Mount Bracket Bolts

**Models Affected: Specific Freightliner Custom Chassis B2 school bus chassis, MB shuttle bus chassis, S2 shuttle bus chassis, and MT45 / MT55 step vans manufactured between March 3, 2008, and August 13, 2008, with Cummins ISB engines.**

### General Information

Daimler Trucks North America LLC, on behalf of its wholly owned subsidiary, Freightliner Custom Chassis Corporation, is initiating Field Service Campaign SF405A to modify the vehicles mentioned above.

Certain vehicles may have been built with motor mount bracket bolts that weren't adequately torqued.

The motor mount bracket bolts will be inspected and existing bolts will be retorqued. Any missing bolts will be replaced.

There are approximately 5,000 vehicles involved.

### Additional Repairs

Dealers must complete all outstanding field service campaigns prior to the sale or delivery of a vehicle. A Dealer will be liable for any progressive damage that results from its failure to complete campaigns before sale or delivery of a vehicle.

Owners may be liable for any progressive damage that results from their failure to complete campaigns within a reasonable time after receiving notification.

Please contact Warranty Campaigns for consideration of additional charges prior to performing the repair.

### Work Instructions

Please refer to the attached work instructions. Prior to performing the campaign, check the vehicle for a completion sticker (Form WAR261).

### Replacement Parts

Replacement parts are now available and can be obtained by ordering the part numbers listed below from your facing Parts Distribution Center.

If our records show your dealership has ordered any vehicle(s) involved in campaign SF405A, a list of the customers and vehicle identification numbers will be available on AccessFreightliner.com. Please refer to this list when ordering parts for this campaign.

**Table 1 - Replacement Parts for SF405A**

**IMPORTANT:** Order the parts listed below for the campaign repairs. There are no kits for this campaign.

Campaign Number	Kit Number	Part Description	Part Number	Qty.	Suggested Wholesale*
SF405A	There are no kits for this campaign. Please order components by part number as needed.	Hexhead Bolt M12 x 100	23-12381-100	1 ea	\$4.33 US \$5.33 CAN
		Hexhead Bolt M12 x 65	N210931 012001	1 ea	\$6.53 US \$8.03 CAN
		Hexhead Bolt M12 x 80	N210931 012003	1 ea	\$3.96 US \$4.87 CAN

\* Please charge all Direct Warranty Customers the above-listed price for the kit, as they are authorized to perform their own Field Service Campaigns.

**Table 1**

# Field Service Campaign

Daimler Trucks  
North America LLC

March 2009  
SF405A

## Removed Parts

Please follow Warranty Failed Parts Tracking shipping instructions for the disposition of all removed parts.

## Labor Allowance

Table 2 - Labor Allowance

Campaign Number	Procedure	Time Allowed (hours)	SRT Code	Damage Code
SF405A	Inspect all bolts and retorque any loose motor mount bolts	0.2	996-0775A	000-Modifiedx
SF405A	Inspect all bolts, retorque any loose bolts, and replace up to two motor mount bolts	0.4	996-0775B	000-Modifiedx
SF405A	Inspect all bolts, retorque any loose bolts, and replace three or more motor mount bolts	0.6	996-0775C	000-Modifiedx

Table 2

**IMPORTANT:** When the campaign has been completed, locate the base completion label in the appropriate location on the vehicle, and attach the gray completion sticker provided in the field service kit (Form WAR261). If the vehicle does not have a base completion label, clean a spot on the appropriate location of the vehicle and first attach the base completion label (Form WAR259). If a field service kit is not required or there is no completion sticker in the kit, write the campaign number on a blank sticker and attach it to the base completion label.

## Claims for Credit

You will be reimbursed for your labor, parts, and handling by submitting your claim through the Warranty system within 30 days of completing the campaign. Please reference the following information in QuickClaim:

- Claim type is **Field Service**.
- In the FTL Authorization field, enter the campaign number and appropriate condition code (**SF405A**).
- In the Primary Failed Part Number field, enter **25-SF405-000**.
- In the Parts field, enter the appropriate **part number(s)** as shown in the Replacement Parts Table. If you are replacing any missing bolts, you may include up to \$5.00 of Loctite® 271 on your claim without authorization.
- In the Labor field, first enter the appropriate SRT from the Labor Allowance Table. For administrative time, enter SRT 939-0010A for 0.3 hours.

This Field Service Campaign will **terminate on March 31, 2010**. Dealers will be notified of any changes to the termination date via Important Campaign Information Letter posted on AccessFreightliner.com.

**IMPORTANT:** ServicePro® must be viewed prior to beginning work to ensure the vehicle is involved and the campaign has not previously been completed. Also, check for a completion sticker before beginning work.

All claims must be submitted within 30 days of the repair and within 30 days of the termination date of the campaign. All excess inventory to be returned to the PDC following the conclusion of the campaign must be returned in resaleable condition to the Memphis PDC within 90 days from the termination date. Please submit a PAR to request return to the Memphis PDC. (Canadian dealers should return the kits to their facing PDC.)

Contact the Warranty Campaigns Department at (800) 547-0712, from 7:00 a.m. to 4:00 p.m. Pacific Time, Monday through Friday, Web inquiry at AccessFreightliner.com / Support / Submit an Inquiry, or the Customer Assistance Center at (800) 385-4357, after normal business hours, if you have any questions or need additional information.

## Copy of Letter to Owner

### Subject: Motor Mount Bracket Bolts

Daimler Trucks North America LLC, on behalf of its wholly owned subsidiary, Freightliner Custom Chassis Corporation, is initiating Field Service Campaign SF405A to modify specific Freightliner Custom Chassis B2 school bus chassis, MB shuttle bus chassis, S2 shuttle bus chassis, and MT45 / MT55 step vans manufactured between March 3, 2008, and August 13, 2008, with Cummins ISB engines.

Certain vehicles may have been built with motor mount bracket bolts that weren't adequately torqued.

The motor mount bracket bolts will be inspected and existing bolts will be retorqued. Any missing bolts will be replaced.

Parts are now available for authorized dealers to order. Contact your authorized dealer to arrange to have the campaign performed as soon as possible and to ensure that parts are available at the dealership. To locate a dealer, search online at [www.FreightlinerCustomChassis.com](http://www.FreightlinerCustomChassis.com) or [www.FreightlinerTrucks.com](http://www.FreightlinerTrucks.com) or contact the Warranty Campaigns Department for assistance.

When you contact your dealer, refer to Field Service Campaign **SF405A** and your vehicle identification number. The campaign will take up to an hour depending on the work required and will be performed at no charge to you.

This Field Service Campaign will **terminate on March 31, 2010**. Please make sure your vehicle(s) is modified prior to this date. Modifications completed after this date will be done at the customer's expense.

As stated in the terms of your express limited warranty, Daimler Trucks North America LLC will not pay for any damage caused by failure to properly maintain your vehicle. Daimler Trucks North America LLC considers the work necessary under this campaign to be proper maintenance and will, therefore, not pay for any damage to your vehicle caused by your failure to have the repairs that are the subject of this campaign performed in a reasonable time.

**IMPORTANT:** When the campaign has been completed on your vehicle, please ensure that a completion sticker has been affixed to your vehicle referencing **SF405A**.

Contact the Warranty Campaigns Department at (800) 547-0712, from 7:00 a.m. to 4:00 p.m. Pacific Time, Monday through Friday, e-mail address [DTNA.Warranty.Campaigns@Daimler.com](mailto:DTNA.Warranty.Campaigns@Daimler.com), or the Customer Assistance Center at (800) FTL-HELP or (800) STL-HELP, after normal business hours, if you have any questions or need additional information.

WARRANTY CAMPAIGNS DEPARTMENT

Enclosure

March 2009  
SF405A

## Work Instructions

### Subject: Motor Mount Bracket Bolts

**Models Affected:** Specific Freightliner Custom Chassis B2 school bus chassis, MB shuttle bus chassis, S2 shuttle bus chassis, and MT45 / MT55 step vans manufactured between March 3, 2008, and August 13, 2008, with Cummins ISB engines.

#### Motor Mount Bracket Bolt Inspection

IMPORTANT: There are no kits for this campaign. Any missing bolts must be ordered as needed.

1. Shut down the engine, set the parking brake, and chock the tires.
2. Check the base label (Form WAR259) for a completion sticker for campaign SF405 (Form WAR261) indicating this work has been done. The base label is usually located above the driver's window or in the driver's area. If a completion sticker is present for campaign SF405, no further work needs to be done. If there is no sticker for SF405, proceed with the steps below.
3. Inspect the four front engine-mounting-bracket bolts. See **Fig. 1** for Saf-T-Liner C2 school bus and S2 chassis engine mounts. For MB shuttle bus, MT45/MT55 step van, and CNG chassis engine mounts, see **Fig. 2**. First inspect for any loose bolts by using a torque wrench to tighten all of the existing bolts to 60 lbf-ft (81 N·m), if possible. Then inspect for any missing bolts.

If none of the bolts are missing, no further action is needed.

If any of the bolts are missing, proceed to the next step.

4. One at a time, apply Loctite® 271 to any new bolts and install them as shown in **Fig. 1** and **Fig. 2**.
5. Tighten each bolt to 60 lbf-ft (81 N·m).
6. Clean a spot on the base label (Form WAR259). The base label is usually located above the driver's window or in the driver's area. Write the campaign number on a blank completion sticker (Form WAR261) and attach it to the base label.

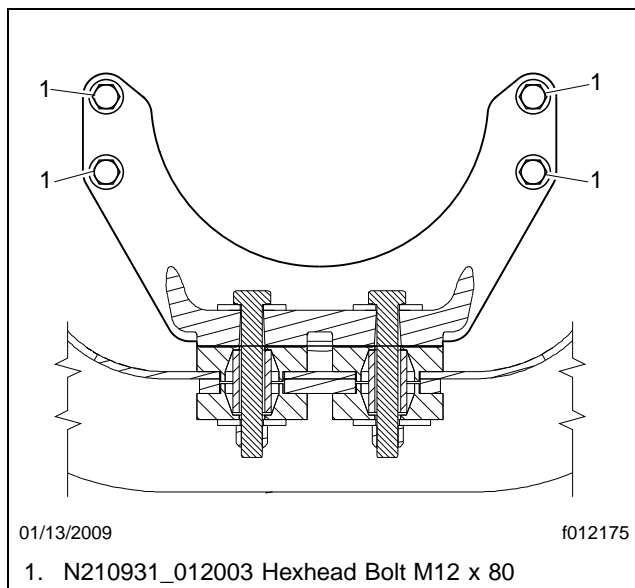

**Fig. 1, Bolts for Saf-T-Liner C2 and S2 Chassis**

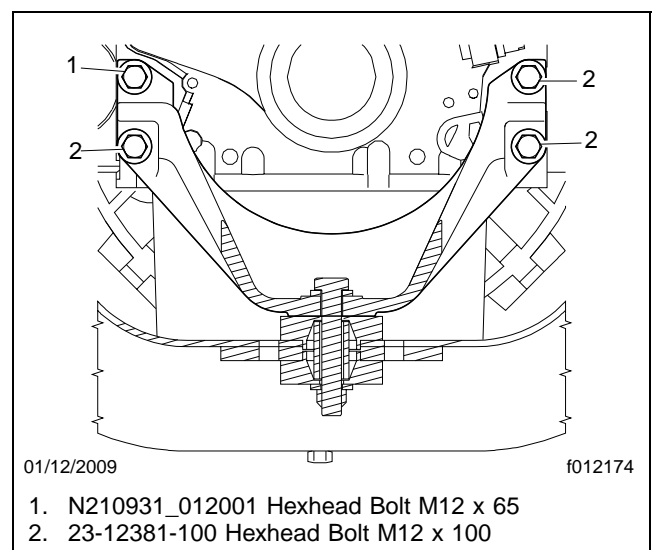

**Fig. 2, Bolts for MB Shuttle Bus, MT45/MT55 Step Van, and CNG Chassis**